

Top quality boiler technology
for a mid-range price!



S3 Turbo



From a renowned company



For nearly five decades Froling has been dedicated to efficiently using wood as an energy source. Today the Froling name stands for modern biomass heating technology. Our firewood, wood chip and pellet boilers are used successfully across Europe. All products are produced at our own factories in Austria and Germany. The excellent coverage of Froling's service network ensures reliability.

S3 Turbo: Top quality boiler technology for a mid-range price

The S3 Turbo firewood boiler focuses on the key points. It contains many features that you would otherwise only find in high-end firewood boilers.

- Patented, cylindrical high temperature turbulence combustion chamber with excellent combustion values.
- Carbonisation gas extraction system for smoke-free reloading.
- Speed-regulated induced draught fan for output control and full operating safety.





The firewood boiler with special benefits:

- 1 Speed-regulated induced draught fan for maximum ease of use.
- 2 WOS (Efficiency Optimisation System) for high efficiency and easy cleaning. (optional for models 18 and 28; fitted as standard from model 36).
- 3 Top quality thermal insulation.
- 4 Manual adjusters for primary and secondary air.
- 5 Generous service openings for easy cleaning.
- 6 S-Tronic controller.
- 7 Carbonisation gas extraction system prevents smoke escaping during reloading.
- 8 Hot cladding for efficient combustion without a build-up of tar in the loading chamber.
- 9 Large fuel loading chamber for pieces of wood up to half a metre in length enables long reloading intervals.
- 10 Patented high temperature swirl combustion chamber ensures low emissions.

A successful design



Feature: Large fuel loading chamber for half metre pieces of wood

- Benefits:
- Easy front-loading
 - Long combustion time
 - Long reloading intervals

The S3 Turbo can easily be front-loaded with half metre pieces of wood. The loading chamber is 55 cm deep and has a generous amount of space. One boiler filling is usually enough for an entire day. Strong steel skirting protects the loading chamber and keeps it clean.

Feature: High temperature swirl combustion chamber

- Benefits:
- Excellent combustion values
 - Low emissions
 - Much more environmentally friendly

Froling uses the patented, cylindrical high temperature swirl combustion chamber in the S3 Turbo. This means the boiler delivers excellent combustion values. The spacious combustion zone guarantees low emissions. So when you use a Froling S3 Turbo you are contributing to clean air.

Feature: Heat-exchanger technology

- Benefits:
- Even more efficient
 - Easy cleaning from outside
 - Fuel economy

The WOS (Efficiency Optimisation System) consists of special turbulators, fitted in the heat exchanger pipes. The lever mechanism makes it easy to clean the heating surfaces from the outside. Another benefit is that the clean heating surfaces reduce the energy consumption. The WOS technology is optional for models 18 and 28, and it comes standardized with model 36.

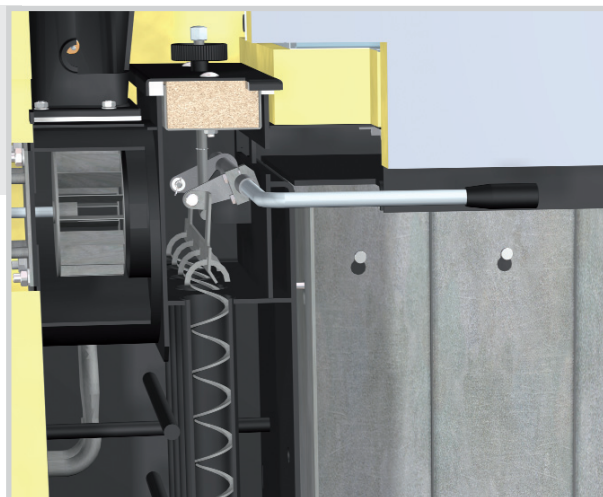



Feature: Special carbonisation gas extraction

- Benefits:
- No smoke escapes during reloading.
 - The boiler room stays clean

The special carbonisation gas extraction system also prevents any smoke from escaping during reloading - whatever the combustion phase. Enjoy modern heating with wood!



Feature: Speed-regulated induced-draught fan

- Benefits:
- Easy to operate
 - Adapts to all operating statuses
 - Safe operating

The primary and secondary air are set by the technician during commissioning. The monitored induced draught fan adjusts to the different operating statuses. This offers excellent output adjustment with safe operating.

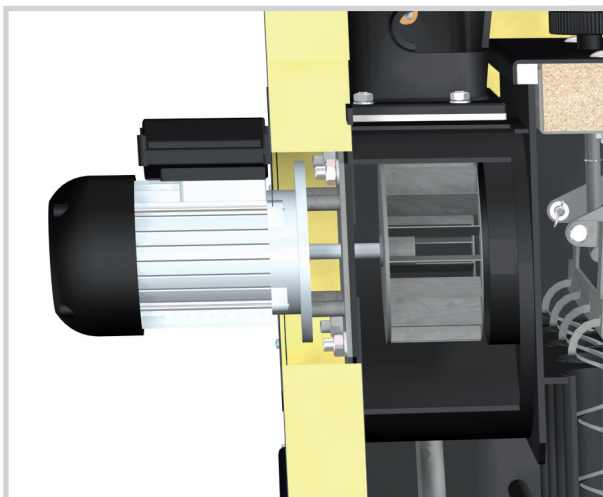

Systematic comfort



Feature: S-Tronic controller

- Benefits:
- The induced draught fan is speed-regulated for output adjustment
 - Integrated storage tank management

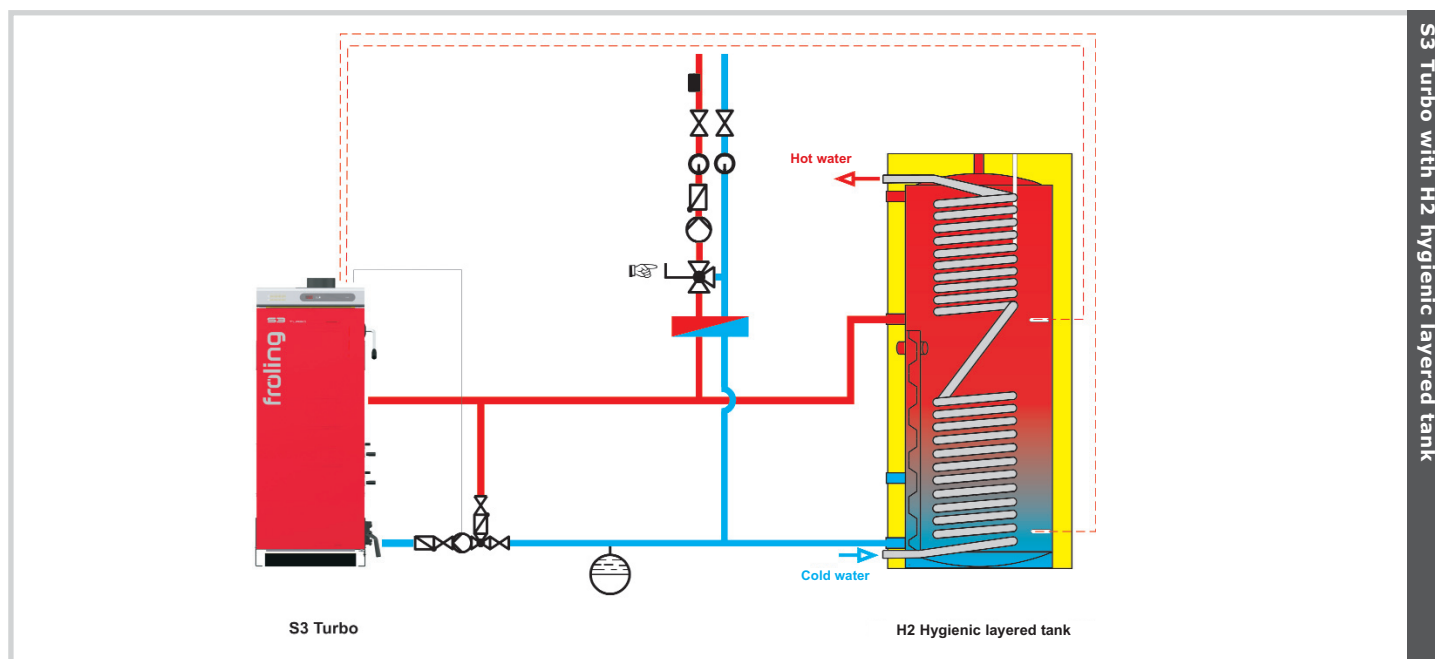

The S-Tronic controller in the boiler controls the induced draught fan and offers the option of connecting a storage tank loading pump and a heating pump. Flue gas and boiler temperature monitoring ensures efficient combustion.

Note: If local regulations state that it is obligatory to use a weather-activated control, then these rules must be observed!

Optional Froling RBG 3200 room console

With the new **RBG 3200 room console** the system is even easier to use.

The heating system can easily be controlled from your living room. It is extremely easy to read off important values and status messages and to change settings at the push of a button.

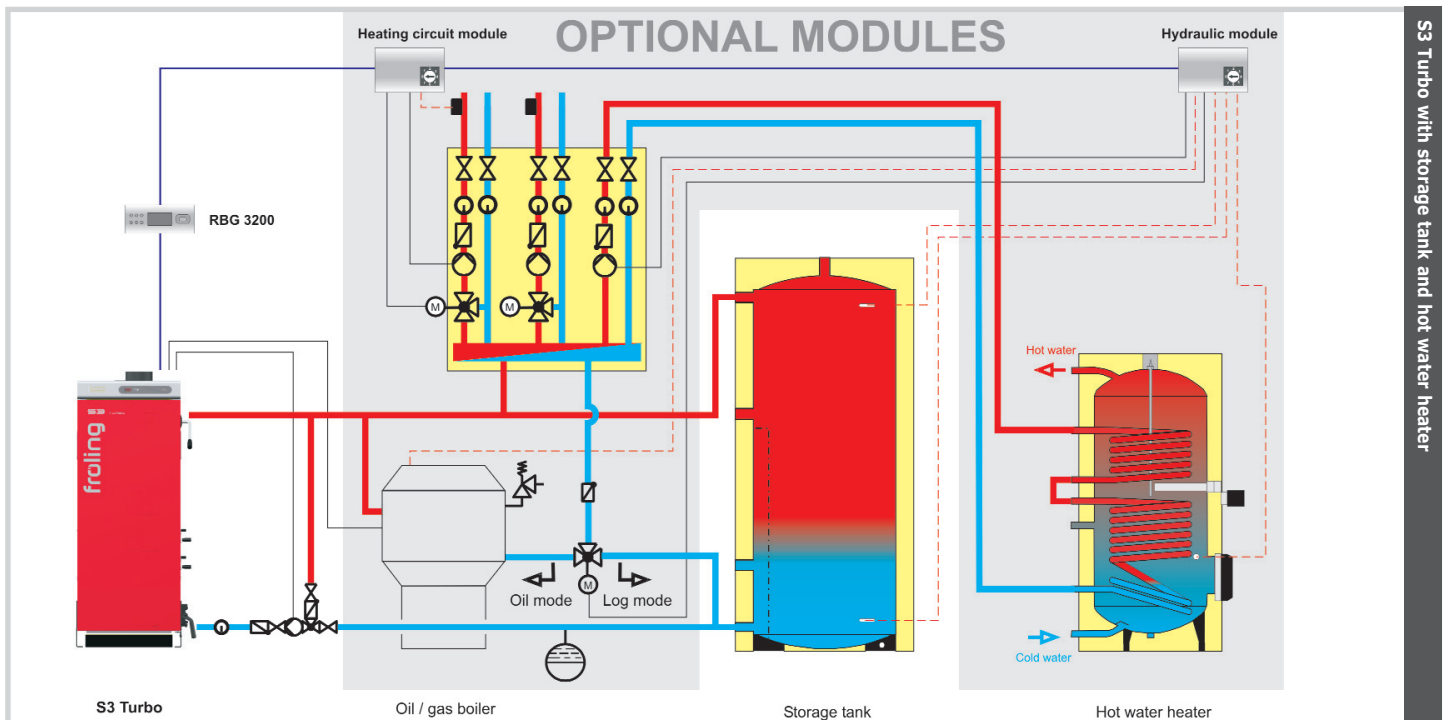

Technical specifications

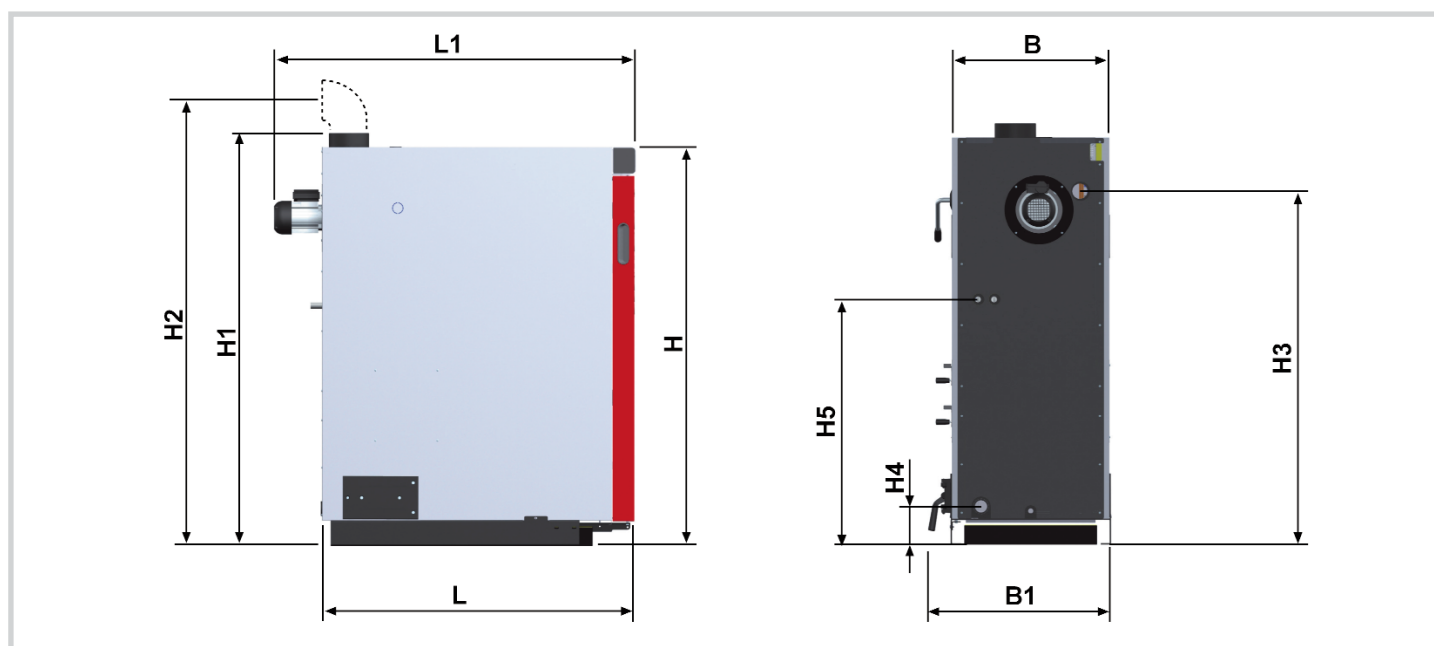

Dimensions - S3 Turbo		18	28	36	45
L	Length, boiler	1160	1160	1250	1250
L1	Total length inc. induced draught fan	1260	1260	1350	1350
B	Width of boiler	570	570	670	670
B1	Total width inc. side cleaning door	680	680	780	780
H	Height of boiler	1470	1470	1570	1570
H1	Total height, inc. flue gas pipe	1530	1530	1630	1630
H2	Height, flue pipe connection	1750	1750	1850	1850
H3	Out feed connection	1280	1280	1380	1380
H4	Return feed connection	140	140	140	140
H5	Safety heat exchanger connection	890	890	980	980
	Flue pipe diameter	150	150	150	150

Technical specifications - S3 Turbo		18	28	36	45
Rated heat output (without WOS equipment)	[kW]	18,0	25,0	-	-
Rated heat output (with WOS equipment)	[kW]	22,5	30,0	36,0	45,0
Fuel loading chamber capacity	[L]	140	140	210	210
Fuel loading door (width/height)	[mm]	330 / 370	330 / 370	330 / 370	330 / 370
Water capacity	[L]	120	120	190	190
Boiler weight	[kg]	520	520	610	610

Further technical details on request.
We'll be happy to advise you.

froling 

**Heizkessel- und Behälterbau GesmbH
A-4710 Grieskirchen, Industriestr. 12**

Tel +43 (0) 7248 606 • Fax +43 (0) 7248 606-600
E-mail: info@froeling.com • Internet: www.froeling.com